

# AMPHIBIOUS EXCAVATOR

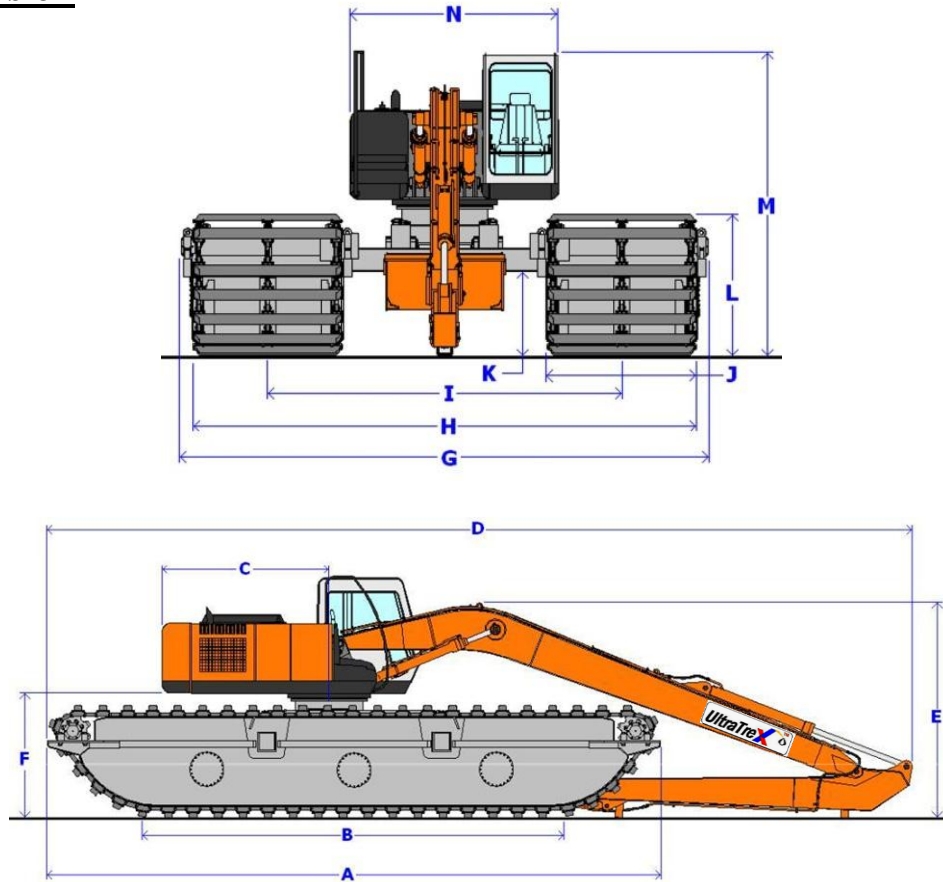

[www.amphibousexexcavator.com](http://www.amphibousexexcavator.com)

## AT300 Dimension



AT300 Amphibious Hydraulic Excavator

Symbol	Description	30tons (66,000 lb) Class Excavator	
		m	Ft
A	Max. Track Length	10.70	35.1'
B	Track Length On Ground	6.80	22.3'
C	Rear Upper Structure Length	3.10	10.2'
D	Overall Length	14.80	48.2'
E	Height of Boom	3.80	12.5'
F	Counterweight Clearance	2.50	8.2'
G	Overall Width (Min/Max)	5.90 / 6.50	19.4' / 21.3'
H	Undercarriage Width (Min/Max)	5.60 / 6.20	18.4' / 20.3'
I	Track Gauge (Min/Max)	3.80 / 4.40	12.5' / 14.4'
J	Track Cleat Width	1.80	5.9'
K	Min. Ground Clearance	1.60	5.2'
L	Track Height	2.30	7.5'
M	Overall Cab Height	4.40	14.4'
N	Upper Structure Overall Width	3.00	9.8'

\*Dimensions are based on 30 ton class excavator, 50' long reach arm.

\*Specifications are subject to change without prior notice.

# AMPHIBIOUS EXCAVATOR



## AT300 Working Range

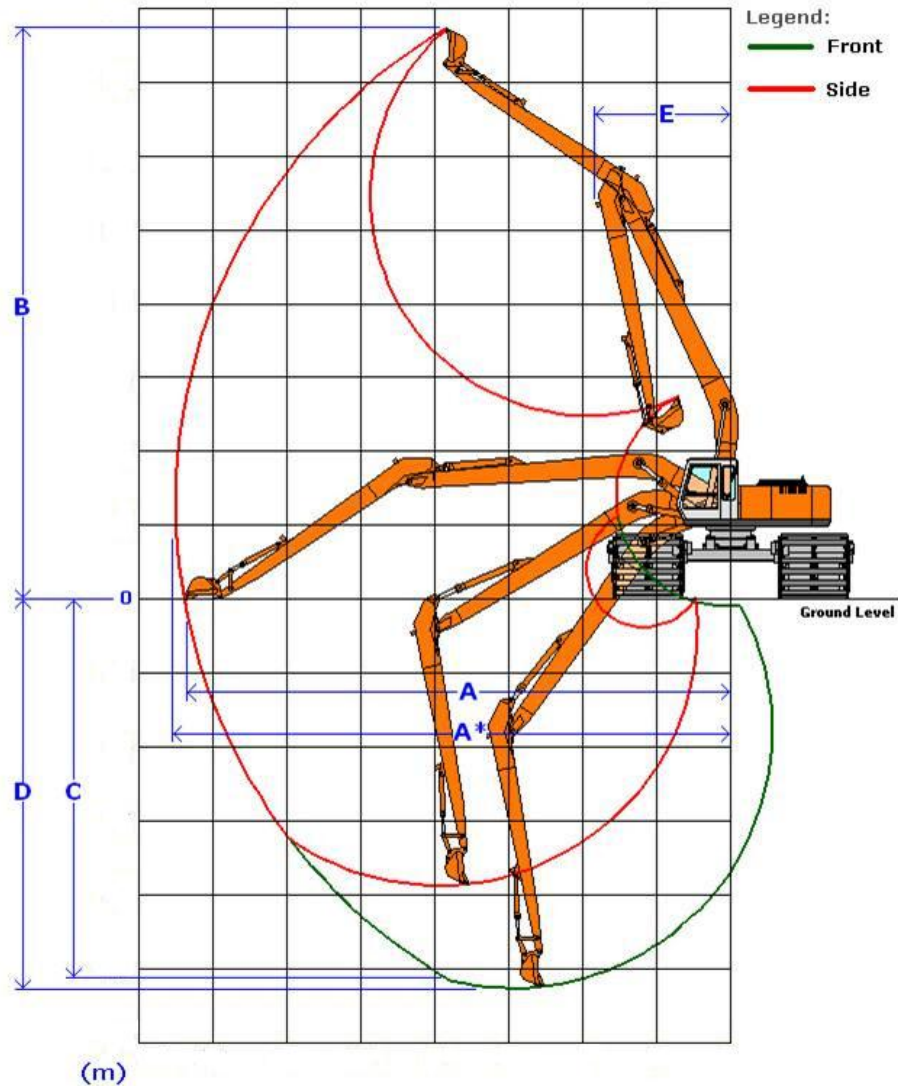

### AT300 Amphibious Hydraulic Excavator

Symbol	Description	30tons (66,000 lb) Class Excavator	
		m	Ft
A	Max. Digging Reach (on ground)	14.87	48.8'
A*	Max. Digging Reach	15.22	50.0'
B	Max. Cutting Height	15.11	49.6'
C	Max Vertical Wall	8.37	27.5'
D	Max. Digging Depth	8.62	28.3'
E	Min. Swing Radius	5.00	16.40'

\*Dimensions are based on excavator 30 ton class excavator, 50' long reach arm.

\*Specifications are subject to change without prior notice.